



APOGEE DYNAMIC OXYGEN CONSERVER

Model 902001

INSTRUCTIONS FOR USE

©2021 by **dYNARIS** ALL RIGHTS RESERVED

PATENTED AND WORLDWIDE PATENTS PENDING



Manufactured by:



Spirit 40 Park Dr.
Suite 108
Chesterfield, MO 63005
1-636-778-1926 (o)
1-636-778-1050 (f)

No part of this text shall be reproduced or transmitted in any form or by any means, electronic or mechanical, including, but not limited to: recording, photocopying, or by any information or retrieval system without written permission from Dynaris.

The information in this manual is confidential and may not be disclosed to third parties without the prior written consent of Dynaris.

Second Edition

The information contained in this manual is subject to change without notice. Dynaris makes no commitment to update or keep current the information contained in this manual.

The only warranty Dynaris makes is the express written warranty extended on the sale of its products.

To order additional copies of this manual (APOG-LAB-001), refer to the contact information above.

 **Caution:** Federal law restricts this device to sale by or on the order of a physician .

 **Caution:** All users must read and understand the Apogee device Instructions for Use, including indications, contraindications, operating instructions, warnings and precautions and cleaning and disinfection instructions before performing any procedure. Failure to do so may result in injury to the patient or operator or cause damage to the Apogee Device.

 **Warning:** The Apogee device must be 'OFF' when the cannula is not in the patients nose.

Table of Contents

1. Symbols Used on Labeling.....	5
2. Labels	6
2.1. Apogee Device Label Identified	6
3. Intended Use	7
3.1. Indications for Use.....	7
3.2. Contraindications	7
3.3. Intended User and Patient Population	7
3.4. Principles of Operation	8
4. Safety Precautions and Warnings.....	8
5. Apogee Device Descriptions	12
6. Apogee Device Components.....	12
6.1. Control Device	12
6.1.1. Warning regarding use of an Oxygen Conserving Device.....	13
6.2. Battery.....	13

- 6.3. Main Control Board (Regulated Voltage Supply) 13
- 6.4. Embedded Processor 13
- 6.5. Apogee Cannula 13
- 6.6. Apogee Bypass Cannula 14
- 6.7. Dynaris Oxygen Regulator..... 14
- 6.8. Oxygen Cylinder Tubing 14
- 6.9. Interface Ports 14
- 6.10 Control Switch..... 14
- 7. Getting Started With the Apogee Device 14
 - 7.1. Initial Inspection of Shipment 14
 - 7.2. Oxygen Cylinder Types Compatible with Apogee Device 15
 - 7.3. Battery Installation and Replacement 15
 - 7.4. Attaching the Nasal Cannula to the Patient 15
 - 7.5. Initiating Apogee Device Treatment 16
 - 7.6. Apogee Device Flow Rate (Bolus) Selector and Breathing Frequency..... 16
 - 7.7. Apogee Triggering Sensitivity 17
- 8. Warnings and Alerts 17
- 9. Powering Off the Apogee Device 17
- 10. Apogee Bypass Flow 18
- 11. Apogee Device Cleaning / Instructions 18
 - 11.1. Cleaning During Use 18
- 12. Troubleshooting the Apogee Device 19
- 13. Preventive Maintenance 20
- 14. Whom to Call for Help 20
- 15. System Specifications 20
 - 15.1. Environmental 20
 - 15.2. System Size and Weight 20
 - 15.3. System IP Classification 21

15.4. System Pneumatic Flow Chart.....	21
16. Apogee Device Disposal	21
17. Apogee device Electrical Specifications	23
17.1. General Technical Precautions.....	23
17.2. Replaceable Parts	23
17.3. Electrommagnetic Compatibility	24
18. Consumer Terms of Use and Conditions of Sale	25
19. Website Terms of Use.....	27
20. Returns	258
21. Limited Warranty	29

Table of Figures

Figure 1: Apogee Device Rear Label	6
Figure 2: Apogee Device Front View	12
Figure 3: Apogee Device Rear View	12
Figure 4: AA Battery	13
Figure 5: Apogee Device Interface Ports	14
Figure 6: Apogee Device in the 'OFF' Position	17
Figure 7: Apogee Bypass Cannula Instructions	18
Figure 8: System Pneumatic Flow Chart	21

Table of Tables

Table 1: Symbols and Corresponding Meanings 5

Table 2: Warning and Caution Statements 8

Table 3: Software Release 12

Table 4: Apogee Device Alerts 17

Table 5: Failure Modes and Safeguards 19

Table 6: Trouble Shooting Flowchart 19

Table 7: Environmental Operating Conditions 20







Table 8: Apogee Device Size and Weight Chart 20

Table 9: Apogee Device Disposal Instructions 22

Table 10: Apogee Device Replaceable Parts 24

1. Symbols Used on Labeling

Table 1 below shows all symbols and the corresponding meaning of all symbols used in this manual, on the Apogee Device, and on packaging labels. Users must pay careful attention to these symbols as they provide important safety precautions and warnings.

Symbol	Meaning
	Attention, Caution, Warning, Danger, Important, Note, or Refer to Accompanying Documentation
	Refer to Instruction manual / Booklet
	Caution: Federal (USA) law restricts this device to sale by or on the order of a physician.
IP22	Ingress protection: minimum design requirements for indoor use
	Not for general waste
	Non Sterile
	Serial number
	Lot number









	Part number
	Direct current
	Symbol for shock protection type BF
	Symbol for "Manufacturer" This symbol shall be adjacent to the name and address of the manufacturer.
	Symbol indicating the "date of manufacture." The symbol shall be adjacent to the date that the product was manufactured, expressed as four digits for the year.
	Keep Dry
	No smoking or open flames
	Atmospheric pressure limitation, Indicates the range of atmospheric pressure to which the medical device can be safely exposed.
	Humidity limitation, Indicates the range of humidity to which the medical device can be safely exposed.
	Temperature Limit, indicates the temperature limits to which the medical device can be safely exposed (operated).
	Power switch OFF

Table 1: Symbols and Corresponding Meanings

2. Labels

2.1. Apogee device Label Identified

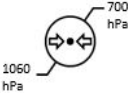
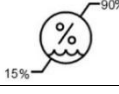
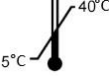
The following label is affixed to the rear of the Apogee device. This label provides the device serial number, operating voltage, manufacturer contact information, and applicable symbols with explanatory text. In the event that the Apogee device needs to be serviced, please have the device serial number available for reference when contacting Dynaris.

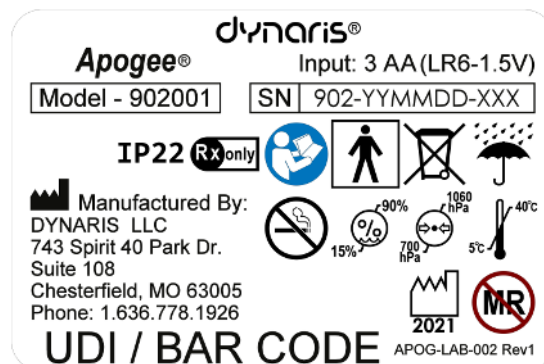

Figure 1: Apogee Device Rear Label

3. Intended Use

3.1. Indications for Use

The Apogee is to be used as part of a portable oxygen delivery system for patients that require supplemental oxygen in their home and for ambulatory use.

The Apogee device shall be used by trained professionals either in a doctor's office or clinical setting initially. However, once recommended by the physician or healthcare provider, the device can be prescribed for use within a home environment for subsequent treatments.

The Apogee device essential performance is to provide short puffs of air during operation as noted on the display for nasal output L or R. In the event air is not delivered, use the bypass adaptor and return the device to Dynaris for immediate replacement.

The Apogee device is a regulated device and carries warnings and cautions regarding safe use of this product. Failure to read this manual and adhere to the warnings and caution stated within manual can affect device performance and may cause potential harm to the user.

The Apogee device and its accessories do not contain any natural rubber latex-containing components.

3.2. Contraindications

The Apogee device is contraindicated for use by patients with the following:

- Tracheotomised patients.
- Patients who breathe through their mouths or oxygen mask.
- Requiring source of oxygen while sleeping.
- Pregnant or nursing women
- Children



Warning: Safety and effectiveness of the Apogee device have not been established for uses outside of those specified herein.

3.3. Intended User and Patient Population

The Apogee device is intended for use in adult patients (age 18 or older) or the patient's operator, as may apply. Patients with contraindications as listed in section 3.2 should not use the Apogee device. All healthcare professionals shall read the Instructions for Use (IFU) and be trained to use the Apogee device to become familiar with its functions prior to use. Training may be conducted in the office by someone familiar with the device and self-training may be conducted by reading and becoming familiar with this document. The Apogee device may be used for home use if prescribed by a doctor and if it is determined that the patient is competent with the device. Patients shall be trained by the healthcare professional on how to properly operate the device prior to home use.



Warning: The device should be kept out of reach of all of those not included in the device prescription by a medical physician, including any pest, pets or children.



Warning: The device should be kept out of reach pets, pests or children as the Apogee device may be damaged by tubing being chewed, entangled or contaminated.

3.4. Principles of Operation

The Apogee is an oxygen conserving device for supplemental oxygen use, compatible with common high pressure O₂ cylinders, which shall integrate with a fixed flow regulator, part number 805003. The Apogee is a simple device to use. The following principles of operation need to be observed:

- Use of this device requires training to become aware of the instruction for use, device warnings and functionality by a trained “operator”.
- The users shall have normal manual dexterity and visual acuity.
- The device uses a dual lumen disposable nasal cannula.
- The selection knob identify the flow rate to be delivered during breathing triggering. This flow setting is selected by the physician and should not be modied unless determined by your physician.
- The Apogee is designed to measure inhalation which can change from body position, congestion and nasal cycle.
- This device isolates nasal passages to maintain a constant baseline of inhalation measures.
- The Apogee device provides a repeatable oxygen bolus within the tolerance specified within this document.
- Reference Section 7 for performance specifications.

4. Safety Precautions and Warnings

The table below lists all of the “warning” and “caution” statements included in this manual and the corresponding section of the instruction manual in which they may be located.



Warning: If at anytime you feel discomfort or are experiencing a medical emergency, seek medical assistance immediately to avoid harm.

Warnings /Cautions	Statement	IFU Section
Caution	Federal law restricts this device to sale by, or on the order of, a physician.	Page 2
Caution	All users must read and understand the Apogee device Instructions for Use, including indications, contraindications, operating instructions, warnings and precautions and cleaning and disinfection instructions before performing any procedure. Failure to do so may result in injury to the patient or operator or cause damage to the Apogee device.	Page 2
Warning	The Apogee device must be ‘OFF’ when the cannula is not in the patients nose.	Page 2
Warning	Safety and effectiveness of the Apogee device have not been established for uses outside of those specified herein.	3.2
Warning	The device should be kept out of reach of all of those not included in the device prescription by a medical physician, including any pests, pets or children.	3.3
Warning	The device should be kept out of reach pets, pests or children as the Apogee device may be damaged by tubing being chewed, entangled or contaminated.	3.3
Warning	If at anytime you feel discomfort or are experiencing a medical emergency, seek medical assistance immediately to avoid harm.	4.0

Warning	The Apogee device does not contain small parts which may become detached, however inhalation or swallowing of small parts by children may be hazardous.	6.0
Warning	Oxygen conserving devices must be used as directed by your physician's prescription.	6.1.1
Warning	Oxygen conserving devices must be used within the manufacturer's recommended high and low breath rates. Refer to section 7.6	6.1.1
Warning	Using a cannula not specified by the manufacture can cause back pressure and will affect the oxygen volume delivered.	6.1.1
Warning	Do not connect items to the Apogee device that are not specified parts of the system as this may result in injury to the user or patient, or cause the system to become inoperable.	6.1.1
Warning	This medical device has cannula tubing for a gas flow attachment. Precautions should be taken in leaving the system exposed to babies or small children to prevent strangulation and asphyxiation or entanglement in the cables due to excessive length. Store the device and cables in the provided storage case away from small children when not in use.	6.1.1
Warning	Do not use any other battery than the one specified in this manual. Using any other battery may damage the device and not provide the treatment operating time.	6.2
Caution	Dropping the Apogee device onto any hard surface may cause mechanical failure, leaks or damage its components. Contact Dynaris if the device is dropped onto any hard surface.	7.1
Caution	Medical electrical equipment requires special precautions regarding EMC and needs to be installed and put into service according to the EMC information provided in this manual.	7.1
Warning	Use only the Dynaris cannulas provided with the device or an approved Dynaris cannula.	7.4
Warning	The use of accessories, detachable parts and materials other than those specified, with the exception of those sold by Dynaris as replacement parts, may result in increased emissions, decreased performance, or decreased immunity of the Apogee device. Do not use accessories other than those specified.	7.4
Caution	Never use organic solvents (e.g. acetone), ammonia compounds, strong acids or bases to clean any portion of the Apogee device as these agents can cause damage to the device.	11.0
Caution	The Apogee device is not certified "waterproof." Never immerse the Apogee device in water or any other fluids.	11.1
Caution	Do not attempt to sterilize the Apogee device or tubings in a steam autoclave or gas chamber. Using an autoclave or gas sterilization can irreversibly damage the Apogee device and cause it to become inoperable. The Apogee device and tubing are classified as non-sterile.	11.1
Caution	Do not use hard instruments for cleaning the Apogee device as this could cause damage to the exterior surfaces and/or cause the display to become inoperable.	11.1

Warning	Before cleaning the Apogee device always switch electrically operated equipment off.	11.1
Caution	The Apogee device is spray resistant, but not “waterproof.” Never spray cleaning agents or other fluids directly into openings on the Apogee device due to risk of damage to the internal electronics. Only external parts of the Apogee device should be cleaned.	11.1
Warning	If a problem occurs with the Apogee device, identify the symptom then attempt to resolve the problem as indicated in the Instructions for Use. If the problem cannot be resolved, under <u>NO</u> condition should the device continued to be used.	12.0
Caution	Precautions should be taken regarding the exposure of the medical equipment to reasonably foreseeable environmental conditions (e.g. mto magnetic fields, electromagnetic fields, external electrical influences, electrostatic discharge, pressure or variations in pressure, acceleration, and thermal ignition sources.)	15.1
Caution	Portable and mobile RF communications equipment can affect medical electrical equipment.	15.1
Warning	The use of accessories, transducers and cables other than those specified, with the exception of those sold by Dynaris as replacement parts for internal components, may result in increased emissions or decreased immunity of the Apogee device.	17.1
Caution	The device enclosure may feel warm to the touch. The maximum surface temperature does not exceed 43°C (109°F). If the device is too hot to hold, contact Dynaris for service.	17.1
Warning	Do not remove system covers. The manufacturer or an authorized service representative only must perform service and maintenance.	17.1
Warning	Do not service or conduct maintenance while the Apogee device equipment is in use.	17.1
Warning	Do not interconnect the Apogee device with other equipment or accessories that are not specified in this manual.	17.1
Warning	Do not attempt to attach the Apogee device to a power source, computer serial port or printer while administering treatment. This may result in serious injury or death from electrical shock.	17.1
Warning	Medical electrical equipment requires special precautions regarding EMC and needs to be installed and put into service according to the EMC information provided in this instructions for use.	17.1
Warning	Do not open or modify the Apogee device.	17.1
Warning	Do not use in an oxygen enriched environment.	17.1
Caution	Wireless communications equipment can affect the Apogee device and such devices should be kept at a safe distance 7.5 feet (2.3m) from such devices.	17.1

Warning	Portable RF communications equipment (including peripherals such as antenna cables and external antennas) should be used no closer than 30 cm (12 inches) to any part of the Apogee System, including cables specified by the manufacturer. Otherwise, degradation of the performance of this equipment could result	17.3
Warning	The Apogee should not be used adjacent to or stacked with other equipment. If adjacent or stacked use is necessary, the Apogee should be observed to verify normal operation. If operation is not normal, the Apogee or the other equipment should be moved.	17.3
Warning	Use of accessories, transducers and cables other than those specified or provided by the manufacturer of this equipment could result in increased electromagnetic emissions or decreased electromagnetic immunity of this equipment and result in improper operation.	17.3
Warning	Operation in close proximity (e.g. 1m or 3.3 ft.) to a shortwave or microwave therapy equipment may produce instability to the Apogee oxygen delivery.	
Warning	There is a risk of fire associated with oxygen equipment and therapy. Do not use near sparks or open flames.	
Warning	Smoking during oxygen therapy is dangerous and is likely to result in serious injury or death of the patient and others from fire.	
Warning	The settings on the Apogee device do not correspond with continuous flow of oxygen.	
Warning	Use only water based lotions or salves that are oxygen compatible during setup or use during oxygen therapy. Never use petroleum or oil based lotions or salves to avoid risk of fire and burns.	
Warning	Do not lubricate replaceable fittings, connections, tubing or other accessories of the dynamic oxygen conserver to avoid the risk of fire and burns.	
Warning	Use only spare parts recommended by the manufacture to ensure proper function and to avoid the risk of fire and burns.	
Warning	Using the Apogee by open windows or in front of fans can create strong draughts and adversely affect accurate delivery of oxygen therapy.	
Warning	To ensure receiving the therapeutic amount of oxygen delivery, the Apogee model 902001 must, <ul style="list-style-type: none"> • be used only after one or more settings have been individually determined or prescribed for you at your specific activity levels. • be used with the specific combination of parts and accessories that are in line with the specification of Dynaris and using your settings which were determined by your physician. 	
Warning	Use of the Apogee device at an altitude above 700hPa (9878 ft) maximum rated altitude, or outside the operating temperature range of 5°C to 40°C (41°F to 104°F), is expected to adversely affect the quality of the therapy.	
Warning	Oxygen makes it easier for a fire to start and spread. Do not leave the nasal cannula on bed coverings or chair cushions. If the Apogee is turned on, but not in use; the oxygen will make the materials flammable. Turn the Apogee off when not in use.	
Warning	Apogee should be kept free from lint, dust and direct exposure to sunlight.	

Warning	The settings of other models or brands of oxygen therapy equipment do not correspond with the settings of this Apogee model 902001.	
Warning	If you feel discomfort or are experiencing a medical emergency, seek medical assistance immediately to avoid harm.	
Warning	Geriatric or any other patient unable to communicate discomfort can require additional monitoring to avoid harm.	
Caution	Geriatric proper placement and positioning of the PATIENT interface is important to the consistent operation of this equipment.	

Table 2: Warning and Caution Statements

5. Apogee Device Descriptions

The Apogee device is a FDA Class II device and an electrical, software controlled battery operated medical device per International Electrotechnical Commission (IEC) standard.

Software Version
1.0.0

Table 3: Software Release

6. Apogee Device Components

The Apogee device is composed of the main components as detailed in the sections below:

Warning: The Apogee device does not contain small parts which may become detached, however inhalation or swallowing of small parts by children may be hazardous.

6.1. Control Device

The control device will house the main control electronics and interface ports that are needed to perform oxygen conservation. The main components of the control device are: Batteries, Main Control Board, Embedded Processor, Apogee Cannula, Apogee Bypass Cannula, Dynaris Oxygen Regulator, Oxygen Cylinder Tubing, Interface Ports, and Control Switch (Settings, ON/OFF).

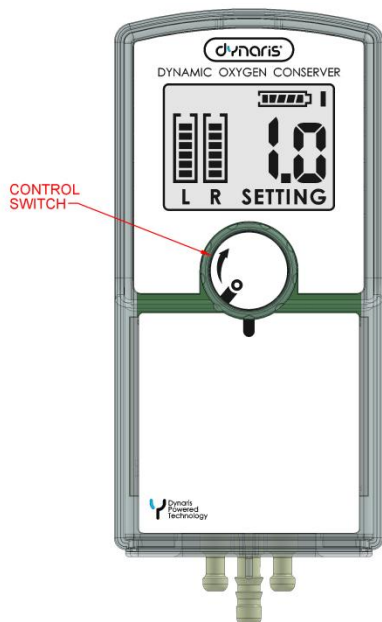

Figure 2: Apogee device Front View

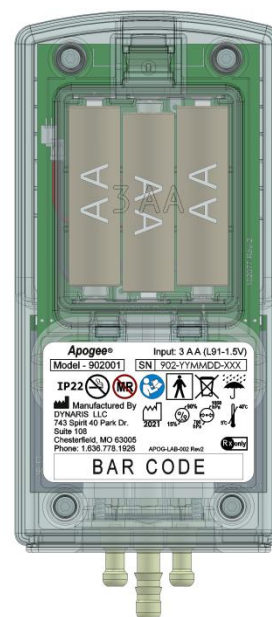







Figure 3: Apogee device Rear View

6.1.1 Warning regarding use of an Oxygen Conserving Device

-  **Warning:** Oxygen conserving devices must be used as directed by your physicians prescription.
-  **Warning:** Oxygen conserving devices must be used within the manufacturer's recommended high and low breath rates. Refer to section 7.6.
-  **Warning:** Using a cannula not specified by the manufacture can cause back pressure and will affect the oxygen volume delivered.
-  **Warning:** Do not connect items to the Apogee device that are not specified parts of the system as this may result in injury to the user or patient, or cause the system to become inoperable.
-  **Warning:** This medical device has a cannula tubing for a gas flow attachment. Precautions should be taken while leaving the system exposed to babies or small children to prevent strangulation and asphyxiation or entanglement in the cables due to excessive length. Store the device and cables in the provided storage case away from small children when not in use.

The Apogee device is provided with three (3) AA batteries. When the batteries are drained, remove them from the device immediately and replace the batteries with the ones provided.

6.2. Batteries

The Apogee device control device utilizes three (3) AA batteries to meet the device power requirements. The recommended battery is a Dynaris P/N 108040 (Zeus AA) or Dynaris P/N 108041 (Energizer AA) or a Dynaris approved equivalent.

-  **Warning:** Do not use any other battery than the one specified in this manual. Using any other battery (including rechargeable batteries) may damage the device.



Figure 4: AA Battery

NOTE: When the Apogee device is stored for an extended period of time remove the batteries prior to storage.

6.3. Main Control Board (Regulated Voltage Supply)

The control board contains a microprocessor and circuitry to take the input voltages from three (3) AA batteries to provide all the regulated voltages for the Apogee device.

6.4. Embedded Processor

The embedded processor is the master controller of the Apogee device. The processor has sufficient I/O inputs to interface with the analog and digital control of the system. The processor operates at the necessary speeds to provide the required sinusoidal waveform.

6.5. Apogee Cannula

The Dynaris Cannula is a disposable accessory that should be replaced periodically following normal usage. Disposable cannulas should be disposed of in accordance with local ordinances and local regulations for disposal. Replacement cannulas can be obtained from the manufacturer.

6.6. Apogee Bypass Cannula

The Apogee Bypass Cannula is an accessory that is to be used in the event that the Apogee device isn't working properly. The Apogee Bypass Cannula is to be used in a Continuous mode and connects to one end of the Apogee Bypass Cannula connector.

6.7. Dynaris Oxygen Regulator

The Dynaris Oxygen Regulator is specifically designed to perform in conjunction with the Dynaris Apogee Device. Using a different regulator may cause unintended performance of the Apogee Device.

6.8. Oxygen Cylinder Tubing

The Oxygen Cylinder Tubing is an accessory that is to be used in the event that the Apogee device isn't working properly. The Oxygen Cylinder Tubing is to be used in a Continuous mode and connects between the Oxygen Cylinder and the Apogee Bypass Cannula Restrictor.

6.9. Interface Ports

Cannula and Oxygen ports are located on the bottom of the Apogee Device. The Apogee cannula has a unique plug which provides for proper connection of the cannula to the Left and Right Nasal Ports (See Fig-5)

6.10. Control Switch

The Apogee is activated by the Control Switch located on the front of the device. Rotating the Control Switch clockwise will activate the device. Continue to rotate the Control Switch to the desired setting (See Fig-2).

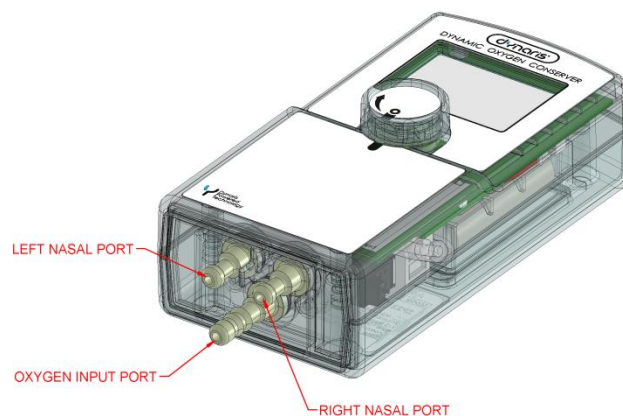

Figure 5: Apogee device Interface Ports

7. Getting Started With the Apogee Device

The following sections detail the instructions for the receipt of the Apogee device, initial inspection, set-up, and powering on the device. The user is advised to set up the Apogee device as recommended in order to achieve safe and optimal use.

7.1. Initial Inspection of Shipment

Upon receipt of the Apogee device, remove the device from the shipping case and inspect contents for damage. If damage is visible, notify the carrier as well as Dynaris (reference Section 13, *Whom to Call for Help*). Keep the damaged materials until the contents of the shipment are checked for mechanical and electrical integrity. If no damage is noted, verify that all the system components and appropriate quantities of each component are present as specified in the accompanying shipment receipt and acknowledgement form. If the shipment is incomplete or components are missing, contact Dynaris.

! Caution: Dropping the Apogee device onto any hard surface may cause mechanical failure of the device, oxygen leaks or damage its components. Contact Dynaris if the device is dropped onto any hard surface.

! Caution: Medical electrical equipment requires special precautions regarding EMC and needs to be installed and put into service according to the EMC information provided in this manual.

Note: It may take up to 15 minutes to warm or cool the device from the storage range temperature of -25°C (-13°F) minimum or 70°C (158°F) maximum between uses when the ambient temperature is 20°C (68°F). The Apogee device when stored at room temperature for normal use is active immediately upon being turned “ON”.

7.2. Oxygen Cylinder Types Compatible with Apogee Device

The following oxygen cylinder types may be used with the Apogee device. Speak to your health care provider as to which cylinder is most applicable to the patients needs and long term treatment.

All cylinder type listed below are regulator type CGA 870 compatible.

Cylinder Type	Cylinder Volume (Liters)
M2	45
M4(A)	113
M6/B	164
ML6	170
M9/C	246
D	425
E	680

7.3. Battery Installation and Replacement

The battery should be replaced when indicated by the battery low level ICON on the display.

- Make sure the Apogee device switch is in the “OFF” position.
- Depress the clip on the battery cover and pull the battery cover away from the Apogee device.
- Remove the batteries and dispose of properly.
- Replace the batteries using the approved batteries as described herein and install them according to the polarity signs (‘plus +’ and ‘minus –’) as indicated.
- Align the battery cover tabs with the notches in the Apogee device and then press the battery cover latch into the Apogee device until the latch completely closes with an audible ‘snap’ and a tactile feel.
- Proceed to turn the Apogee device “ON” if the Apogee device is required for use.

7.4. Attaching the Nasal Cannula to the Patient

The nasal cannula is used to deliver supplemental oxygen to the patient. The cannulas are disposable and should be replaced using the part number stated in section 16.2.

Follow the steps below to securely attach the nasal cannula to the patient.

- Make sure the Apogee device switch is in the “OFF” position.
- Wash your hands then remove the nasal cannula from its package.
- Attach the end connector to the Apogee device output ports (left and right) nasal ports.
- Position the nasal cannula with the prongs facing upward and curved toward the face.
- Insert the nasal prongs into the nostrils.
- Wrap the headset loop up and over both ears. See reference image below.
- Secure headset loop behind your head.

- Slide the guide support up under the chin to hold the nasal cannula in place.
- Proceed to turn the Apogee device “ON” if the Apogee device is required for use.
- The cannula should be replaced as needed every 1 to 2 weeks.

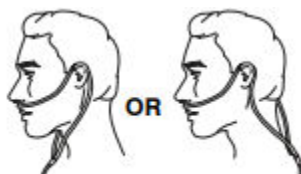

Warning: Use only the Dynaris cannulas provided with the device or an approved Dynaris cannula.

Warning: The use of accessories, detachable parts and materials other than those specified, with the exception of those sold by Dynaris as replacement parts, may result in increased emissions, decreased performance, or decreased immunity of the Apogee device. Do not use accessories other than those specified.

7.5. Initiating Apogee Device Treatment

Once the cannula is properly placed and the regulator tubing are properly attached to the device, turn the device “ON” by rotating the knob (clockwise) from the “OFF” position (see Figure 6) to the selected regulated flow on the front of the device. Check the display to verify battery level, L or R nasal activation ICONs. If user sees no activation on either nasal passage notify your health care provide or contact Dynaris for assistance.

The Apogee device is also intended for ambulatory usage, and can be worn during all daily activities as directed by your physician or healthcare provider. Note that some respiratory efforts of the Patient might not trigger the Apogee device. Do not use the Apogee device during periods of bathing, showering or any other type of water activity.

7.6. Apogee Device Flow Rate (Bolus) Selector and Breathing Frequency

Once the Apogee device is turned “ON”, rotating the flow rate selector to the selected number will indicate the volume at which the Oxygen will be delivered to the patient (as prescribed by a physician). The Apogee device awaits the inspiration through the cannula by the patient at which time the Apogee device will pulse dose on every breath. Typical breathing evaluation is set at 1ml/breath.

Setting	Breath rate / Dose per breath (ml)						Tolerance
	15	20	25	30	35	40	
1	10.0	10.0	10.0	10.0	10.0	10.0	+/- 15%
1.5	15.0	15.0	15.0	15.0	15.0	15.0	+/- 15%
2	20.0	20.0	20.0	20.0	20.0	20.0	+/- 15%
2.5	25.0	25.0	25.0	25.0	25.0	25.0	+/- 15%
3	30.0	30.0	30.0	30.0	30.0	30.0	+/- 15%
4	40.0	40.0	40.0	40.0	34.0	30.0	+/- 15%
5	50.0	50.0	48.0	40.0	34.0	30.0	+/- 15%
6	60.0	60.0	48.0	40.0	34.0	30.0	+/- 15%

The Apogee device stays within the tolerance over the environmental operating range specified in section 15.1.

7.7. Apogee Triggering Sensitivity

Some respiratory efforts of the PATIENT might not trigger the Apogee device. The minimum triggering pressure level for the Apogee device for all settings is $< -0.3\text{cmH}_2\text{O}$.

8. Warnings and Alerts

The table below provides a list of the Apogee device alerts and warnings and the corresponding corrective action to take if needed.

Alert / Warnings	Tone/Message
Device turned ON	Single beep
Low Battery	Battery ICON level displayed
Low Battery	(Tone) Beep
Patient inhale is not detected	(Tone) Beeps ever 30 sec.

Table 4: Apogee device Alerts

9. Powering Off the Apogee Device

When a treatment has been completed the user should take the following steps to power off the Apogee device:

- Rotate the ON/OFF knob counter clockwise until the LCD Screen goes blank and the indicator bar on the knob aligns with the indicator bar on the front label of the Apogee device.
- If the treatment is completed, take the following step to store the Apogee device:
 - Ensure the device is turned off
 - Disconnect the nasal cannula.
 - Disconnect the tubing from the oxygen regulator.
 - Remove the batteries from the battery compartment (see Section 7.3).
 - Close the battery compartment and store at room temperature until needed.

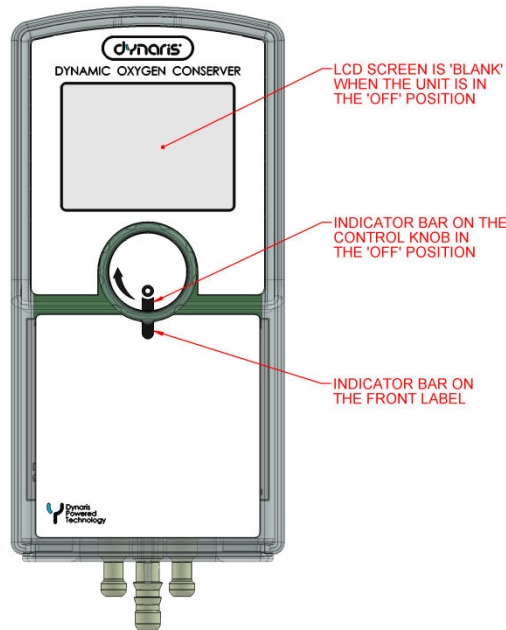

Figure 6: Apogee device in the 'OFF' Position

10. Apogee Bypass Cannula Instructions

If for some reason the Apogee device stops working follow the steps below to continue to receive supplemental oxygen:

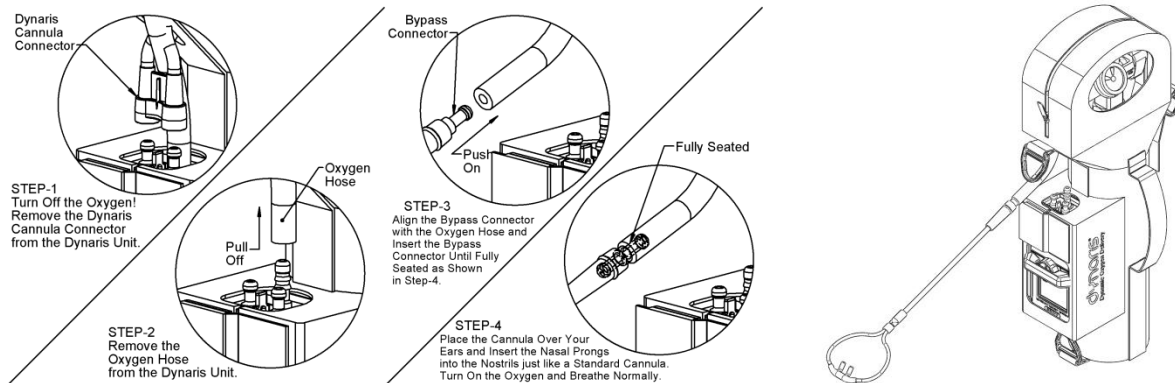

Figure 7: Apogee Bypass Cannula Instructions

The accessory Bypass cannula part number 908912 as shown above provides 3L/min +/- 15% flow to the patient. Contact Dynaris that the Apogee was bypassed and that the device is not functioning.

11. Apogee Device Cleaning / Instructions

Always wash hands prior to handling the Apogee device. The Apogee device should be kept clean and free from moisture and dirt.

The Apogee device is classified as a non-critical device and its components require only cleaning with the recommended cleaning agent. The recommended cleaning agent for the Apogee device is mild soapy water (e.g. Dawn).

Caution: Never use organic solvents (e.g. acetone), ammonia compounds, strong acids or bases to clean any portion of the Apogee device as these agents can cause damage to the device.

11.1. Cleaning During Use

The following cleaning instructions should be followed during use of the Apogee device.

- Wash hands prior to handling any Apogee device components.
- Ensure the Apogee device is off (see Figure 6).
- Use a damp cloth to wipe down the Apogee device with a circular motion.
- Dry using a clean towel or paper towels.
- Clean the device periodically by wiping it down with a dry lint free cloth.

Caution: The Apogee device is not certified “waterproof.” Never immerse the Apogee device in water or any other fluids.

Caution: Do not attempt to sterilize the Apogee device or tubings in a steam autoclave or gas chamber. Using an autoclave or gas sterilization can irreversibly damage the Apogee device and cause it to become inoperable. The Apogee device and tubing are classified as non-sterile.

Caution: Do not use hard instruments (scrapers, scouring pads, etc) for cleaning the Apogee device as this could cause damage to the exterior surfaces and/or cause the display to become inoperable.

Warning: Before cleaning the Apogee Device, always switch electrically operated equipment off (see Figure-6).

Caution: The Apogee device is spray resistant, but not “waterproof.” Never spray cleaning agents or other fluids directly into openings on the Apogee device due to risk of damage to the internal electronics. Only external parts of the Apogee device should be cleaned.

12. Troubleshooting the Apogee Device

Though occurrence is unlikely, Table 5 below identifies potential failure modes for the Apogee device. Each of the failure modes includes a built-in safeguard (as listed below) to ensure patient safety.

Potential Failure Modes	Safeguards
1. Hardware Failure	1. Device Shuts Down, No Output
2. Software Failure	2. Device Shuts Down, No Output

Table 5: Failure Modes and Safeguards

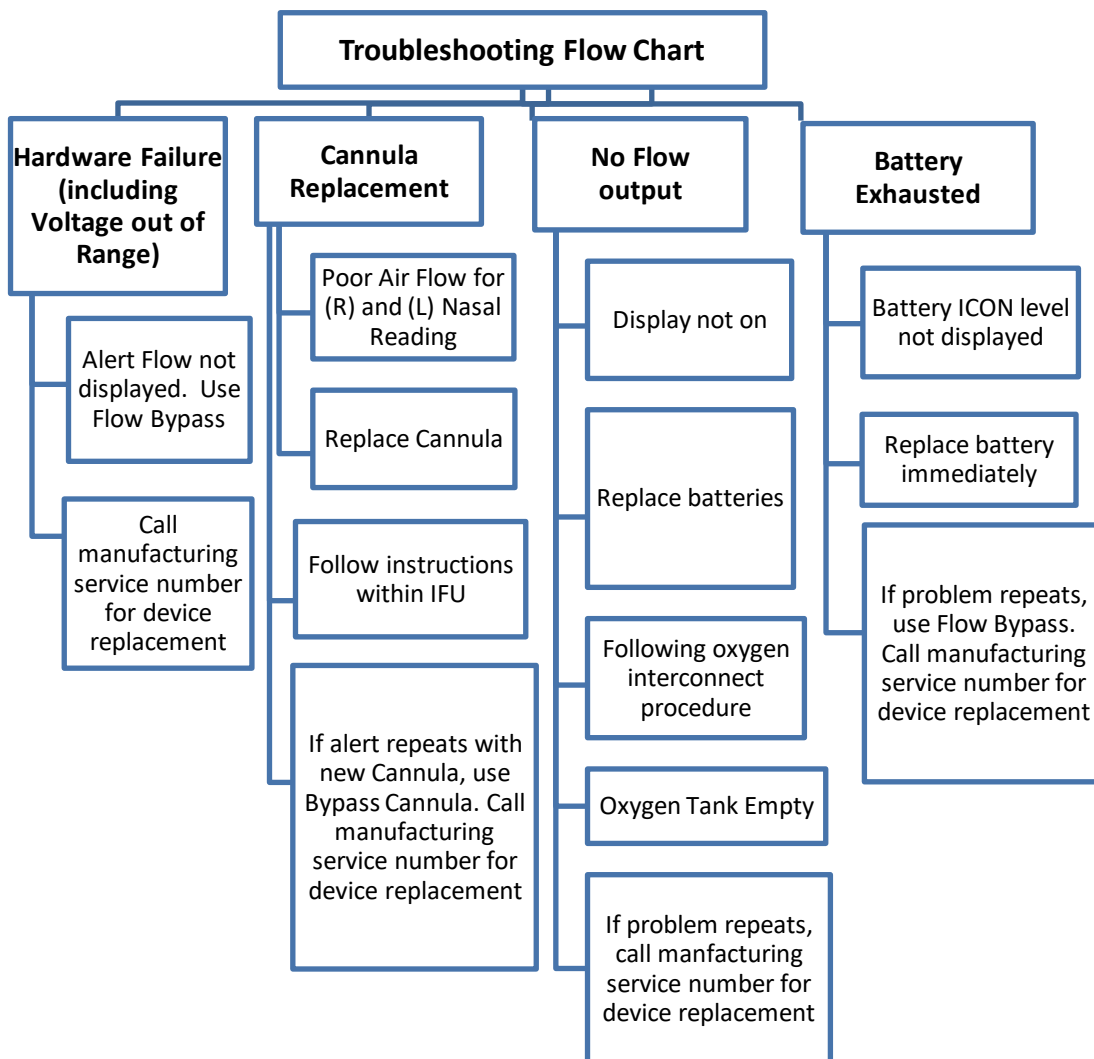



Table 6: Trouble Shooting Flowchart

 **Warning:** If a problem occurs with the Apogee device, identify the symptom then attempt to resolve the problem as indicated in the Instructions for Use. If the problem cannot be resolved, under NO condition should the device continued to be used.

 **Warning:** Listen for leaks. If a leak is present, close the cylinder valve, check the CGA seal, and reinstall. If the leak persists, **DO NOT USE THE EQUIPMENT.**

13. Preventive Maintenance

To ensure safety relating to environmental conditions, use the Apogee device within the appropriate ambient clinical environment. For continued system performance, the Apogee device should be serviced annually undergoing performance and leakage integrating testing. The Apogee device has a service life of 5000 hours when used daily in continuous use. There are no serviceable parts within the Apogee device by the user. Return the Apogee device to the manufacturer for service.

14. Whom to Call for Help

In the event that the device becomes inoperable and cannot be remedied using the troubleshooting guidelines above, contact Dynaris at 1-636-778-1926, the responsible organization for the Apogee device. Have the system serial number (located on the label on the back of the Apogee device) available for reference when contacting Dynaris.

15. System Specifications

15.1. Environmental

Transportation/ Storage	Temperature	-25°C to 70°C (-13°F to 158°F)
	Relative Humidity	Up to 90 % (non-condensing)
	Warning: Batteries should be removed during storage period	
Operating	Temperature	5°C to 40°C (41°F to 104°F)
	Relative Humidity	15-90 % (non-condensing)
Atmosphere Pressure Range	700hPa to 1060hPa	

Table 7: Environmental Operating Conditions

 **Caution:** Precautions should be taken regarding the exposure of the medical equipment to reasonably foreseeable environmental conditions (e.g. mto magnetic fields, electromagnetic fields, external electrical influences, electrostatic discharge, pressure or variations in pressure, acceleration, and thermal ignition sources.)

 **Caution:** Portable and mobile RF communications equipment can affect Medical Electrical Equipment.

15.2. System Size and Weight

Size	146.0mm (5.75")* x 72.3mm (2.85") x 39.6mm (1.56")**
Weight with batteries	321 grams (11.32oz)
Weight without	242 (8.54 oz)

Table 8: Apogee Device Size and Weight Chart

Note: * Does not include height of Bobular Fittings. With Bobular Fittings, 155.0mm (6.10")

Note: ** Does not include height of Selector Knob. With Selector Knob, 48.0mm (1.90")

15.3. System IP Classification

The Apogee device is designed to accept system spillage from accidental wetting in which no liquid is retained within system enclosure that can impair system performance as tested per IEC 60601-1 spillage criteria. The Apogee device has an IP22 classification. IP22 is protected against insertion of fingers and will not be damaged or become unsafe when exposed to vertical or nearly vertical dripping water. IP22 or IPX2 are the minimum requirements for the design for indoor use and is found in compliance to IEC60601-1-11.

15.4. System Pneumatic Flow Chart

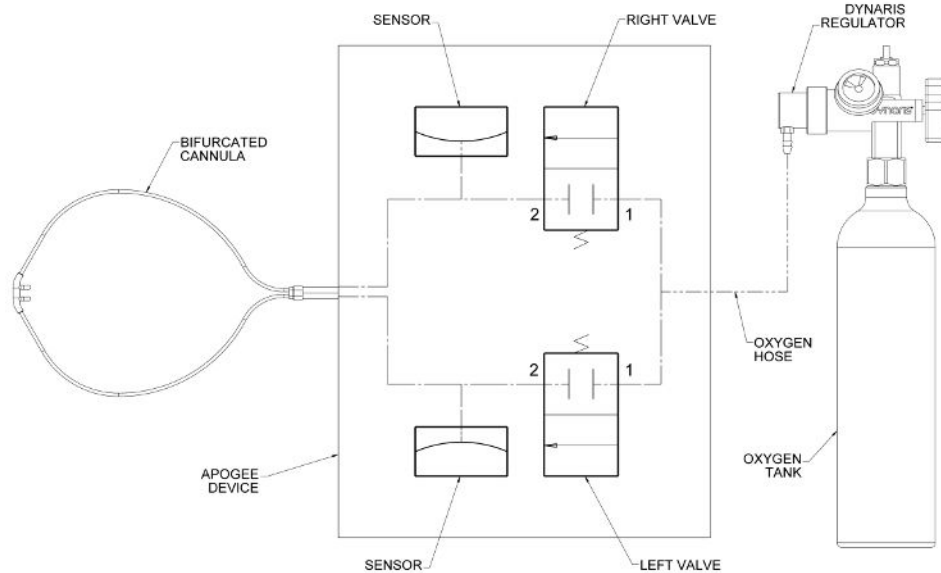

Figure 8: System Pneumatic Flow Chart

16. Apogee Device Disposal

The table below provides important information regarding disposal of the Apogee device components. Note that the Apogee device consists of a plastic enclosure, electrical components, and three (3) AA batteries. DO NOT dispose of any components of the Apogee device in the event it should become damaged beyond the point of repair. Contact Dynaris for shipping instructions to return the Apogee device for service. All accessory tubing provided by Dynaris are specified for use at specific flows defined within this manual.

Description	Product Reference Numbers	Sterilization Method	Frequency of Use	Method of Disposal	Component shelf life once activated components









Apogee Device	902001		Daily Use (<i>expected life is five (5) years with annual servicing thereafter to ensure continued safe operation</i>) for prescribed patient	Return Apogee device to Dynaris for disposal at end of use or service life.	5 Years
Apogee Nasal Cannula, 3'	902028		Reusable (<i>Note: Discontinue use when the cannula becomes dirty</i>).	Dispose of in a regulated medical waste container and / or per local safety regulations.	1-2 Weeks
Apogee Oxygen Cylinder Tubing	108027		Reusable (<i>Note: Discontinue use when the Tubing becomes dirty</i>)	Dispose of in a regulated medical waste container and / or per local safety regulations.	6-Months
Apogee Bypass Cannula, 3'	908912		Reusable (<i>Note: Discontinue use when the Tubing becomes dirty</i>)	Dispose of in a regulated medical waste container and/or per local safety regulations.	N/A
Dynaris Oxygen Regulator	805003		Daily Use (<i>expected life is 5 years of use. Fixed output at 25psi, +/- 3psi</i>)	Return Apogee device to Dynaris for disposal at end of use or service life.	5 Years
Dynaris Regulator Yoke Washer	805012		Reusable (<i>Note: Replace the Washer if it appears cracked or worn</i>)	 Dispose of per local safety regulations	Replace as necessary
Apogee Device AA Alkaline Battery	108040 or 108041		Single use (<i>Replace batteries every 30 operating days. 1-day equals 4 hours at 20 breaths/min</i>)	 Dispose of per local safety regulations	Replace as indicated by the battery ICON











Table 9: Apogee Device Disposal Instructions

Note: Unopened device or accessories maintain a complete shelf life of 5 years.
Oxygen Cylinder Tubing is rated for a maximum range or 32 PSI.
Bypass cannula is restricted to 4.5 L/min (or less).

17. Apogee Device Electrical Specifications

The Apogee device is designed in compliance to IEC 60601-1 electrical safety standards, IEC 60601-1-2, which relates to immunity testing, and IEC60601-1-11 for home use safety. The Apogee device has been tested and meets Class B emission for home use. The Apogee device has also been tested for emission susceptibility testing from other equipment. The device has been found in compliance for basic safety and essential performance.

17.1. General Technical Precautions

-  **Warning:** The use of accessories, transducers and cables other than those specified, with the exception of those sold by Dynaris as replacement parts for internal components, may result in increased emissions or decreased immunity of the Apogee device.
-  **Caution:** The device enclosure may feel warm to the touch. The maximum surface temperature does not exceed 43°C (109°F). If the device is too hot to hold contact Dynaris for service.
-  **Warning:** Do not remove system covers. The manufacturer or an authorized service representative only must perform service and maintenance.
-  **Warning:** Do not service or conduct maintenance while the Apogee device equipment is in use.
-  **Warning:** Do not interconnect the Apogee device with other equipment or accessories that are not specified in this manual.
-  **Warning:** Do not attempt to attach the Apogee device to a power source, computer serial port or printer while administering treatment. This may result in serious injury or death from electrical shock.
-  **Warning:** Medical electrical equipment requires special precautions regarding EMC and needs to be installed and put into service according to the EMC information provided in this instructions for use.
-  **Warning:** Do not open or modify the Apogee device.
-  **Warning:** Do not use in oxygen riched environment.
-  **Caution:** Wireless communications equipment can affect the Apogee device and should be kept at a reasonable distance.

17.2. Replaceable Parts

Apogee Device	P/N	902001
Apogee Nasal Cannula, 3'	P/N	902028
Apogee Oxygen Cylinder Tubing	P/N	108027
Apogee Bypass Cannula, 3'	P/N	908912
Dynaris Oxygen Regulator	P/N	805003
Dynaris Regulator Yoke Washer	P/N	805012
Apogee Device AA Alkaline LR6 Battery	P/N	108040 or 108041

Table 10: Apogee device Replaceable Parts

17.3. Electromagnetic Compatibility

The Apogee is suitable for the electromagnetic environment of typical homes, commercial or hospital settings.

 **Warning:** Portable RF communications equipment (including peripherals such as antenna cables and external antennas) should be used no closer than 30 cm (12 inches) to any part of the Apogee System, including cables specified by the manufacturer. Otherwise, degradation of the performance of this equipment could result.

 **Warning:** The Apogee should not be used adjacent to or stacked with other equipment. If adjacent or stacked use is necessary, the Apogee should be observed to verify normal operation. If operation is not normal, the Apogee or the other equipment should be moved.

 **Warning:** Use of accessories, transducers and cables other than those specified or provided by the manufacturer of this equipment could result in increased electromagnetic emissions or decreased electromagnetic immunity of this equipment and result in improper operation.

Emissions:

Test for	Standard	Compliance Level	Guidance
Radiated RF emissions	CISPR 11	Group 1 Class B (radiated)	The Apogee uses RF energy only for its internal function. Therefore, its RF emissions are very low and are not likely to cause any interference in nearby electronic equipment. The Apogee is suitable for use in all establishments, including domestic establishments and those directly connected to the public low-voltage power supply network that supplies buildings used for domestic purposes.

Immunity:

During the immunity testing described below the Apogee continued to function within specification.

Electro-Static Discharge (immunity)	IEC 61000-4-2	±8 kV contact ±15 kV air	The relative humidity should be at least 5 %
Radiated RF electromagnetic fields (immunity)	IEC 61000-4-3	10 V/m 80 MHz to 2.7 GHz 80 % AM at 1 kHz	The Apogee is suitable for the electromagnetic environment of typical homes, commercial or hospital settings.

Proximity fields from RF wireless communications equipment (immunity)	IEC 61000-4-3	Per IEC60601-1-2:2014 Table 9	The Apogee is suitable for the electromagnetic environment of typical homes, commercial or hospital settings.
Rated power frequency magnetic field (immunity)	IEC 61000-4-8	30 A/m 50 and 60 Hz	<p>Power frequency magnetic fields from common appliances in the home are not expected to affect the device.</p> <p>Power frequency magnetic fields should be at levels characteristic of a typical location in a typical commercial or hospital environment. Keep the Apogee away from sources of high levels of power line magnetic fields (in excess of 30 A/m) to reduce the likelihood of interference.”</p>

18. Consumer Terms of Use and Conditions of Sale

ALL SALES OF PRODUCTS BY INCOBA LLC DBA DYNARIS (“DYNARIS”) TO PATIENT AND CUSTOMER’S USE THEREOF ARE EXPRESSLY CONDITIONED ON CUSTOMER’S ACCEPTANCE OF THE FOLLOWING TERMS AND CONDITIONS, AND ACCEPTANCE OF THE PRODUCT BY PATIENT IS AN ACCEPTANCE OF THE FOLLOWING TERMS AND CONDITIONS. “CUSTOMER” SHALL REFER TO THE PURCHASER OF PRODUCT DIRECTLY FROM DYNARIS.

ORDERS:

Order for products (“Products”) sold by Dynaris to Patient (“Customer”) may be placed with Dynaris via Dynaris’s website or with a Dynaris representative at 636-778-1926. No orders shall be binding upon Dynaris and until accepted by Dynaris, under these terms and conditions, and Dynaris shall have no liability to Patient with respect to orders that are not accepted. Orders for oxygen systems require a prescription.

TERMS:

Unless otherwise noted, Dynaris accepts credit cards, PayPal, money orders, and certified bank checks only, and title to products and risk of loss shall pass to Patient upon delivery of products to the carrier at the point of shipment. Payment is due at time of order. If Dynaris employs any legal process to recover any amount due and payment from Patient under the terms of these terms and conditions, Patient shall pay all costs of collection and reasonable attorney’s fees.

CANCELLATIONS:

Orders cancelled after the order is placed but before we ship to Patient will be charged a 6% cancellation fee. If you cancel your order after it has already shipped, we consider it a return and the above policies apply.

INSPECTION AND ACCEPTANCE:

It is Customer’s responsibility to inspect all Products promptly upon receipt for damage attributable to the carrier and to make claim directly to the carrier for such damage. The furnishing by Dynaris of a Product

to Patient shall constitute acceptance of that Product unless written notice of shipping damage or quantity is received by Dynaris within ten (10) business days of delivery to Customer's designated address, unless otherwise expressly agreed to by Dynaris.

PRODUCT CHANGES AND SUBSTITUTIONS:

Dynaris reserves the right (a) to make changes to Products without notice, and without any obligation to incorporate those changes in any Products previously delivered to Patient and (b) to ship to Patient the most current Product regardless of catalog description.

FORCE OF MAJEURE:

Dynaris shall not be responsible for delays or failures in its performance resulting from Acts of God, war, riot, fire, explosion, accident, flood, sabotage, inability to obtain fuel, power, raw material or machinery, governmental laws, regulations, or labor trouble, strike, lockout or injunction, acts, or omissions beyond Dynaris control, including delays of suppliers or technical failure. If any such delay or failure occurs, Dynaris may allocate Product among Dynaris's Customers at its sole discretion.

INDEMNIFICATION:

Patient shall defend, indemnify, and hold harmless Dynaris from and against any liability, damage, loss, or expense (including reasonable attorneys' fees and expenses of litigation) in connection with any claims, suits, or proceedings arising out of or relating to the use or other exploitation of the Products, unless proximately caused by the sole gross negligence or willful misconduct of Dynaris.

GOVERNING LAW:

The validity, interpretation, and performance of these terms and conditions shall be governed by and construed under the applicable laws of the State of Missouri as if performed wholly within the state and without giving effect of the principles of conflict laws.

NOTICES:

All notices, requests, claims, demands and other communications shall be in writing and shall be given (and shall be deemed to have been duly given upon receipt) by delivery in person, facsimile or by registered or certified mail (postage prepaid, return receipt requested) to the other party at, in the case of Customer, the Customer's billing address on record and, in the case of Dynaris at 743 Spirit 40 Park Drive, Suite 108, Chesterfield, MO 63005.

ARBITRATION:

Except as provided otherwise herein, all disputes between the parties hereto shall be determined solely and exclusively by arbitration unless the parties otherwise agree in writing. The parties shall jointly select an arbitrator. In the event the parties fail to agree upon an arbitrator within ten (10) days, then Dynaris shall select an arbitrator and Patient shall select an arbitrator and such arbitrators shall then select a third arbitrator to serve as the sole arbitrator. Judgement upon the award of the agreed upon arbitrator, or the so chosen third arbitrator, shall be binding and shall be entered into by a court of competent jurisdiction.

EXCEPTION TO TERMS AND AGREEMENTS:

When Dynaris has entered into a separate agreement with a Customer, the terms and agreements referenced within those agreements will supersede the language in this document when referencing to such items as shipping terms, finance arrangements, acceptance of product, notice of changes or substitutions, limited warranty specifications and out of box failure procedures, etc.

ENTIRE AGREEMENT AND AMENDMENTS:

These terms and conditions shall constitute the entire agreement between the parties with respect to the subject matter hereof and supersedes any and all prior and contemporaneous representation,

agreements, negotiations, advertisements, statements, or understandings, whether oral or written. No amendment to these terms and conditions shall be binding on Dynaris unless such amendment is in writing and executed by an authorized representative of Dynaris. Any document containing conflicting terms shall not take precedence over these terms and condition, unless otherwise agreed to in writing by Dynaris. Any breach hereunder may be waived only by a writing signed by the party against whom enforcement is sought.

CONDITIONS OF SALE:

Patient will refer to Dynaris’s IFU manuals for intended use, additional warnings, and precautions. Dynaris sells and services oxygen systems. As with any powered device, the user may experience periods of non-operation because of power interruption, or the need to have the device serviced by a qualified technician.

WARNINGS AND CAUTIONS:

WARNING: Reserve Oxygen Supply; A back-up source of supplemental oxygen is strongly recommended in case of power outage or mechanical failure of any device. Patient should consult Customer’s local home medical equipment provider for back-up source of oxygen.

WARNING: It is the responsibility of the Patient to make back-up arrangements for alternative oxygen supply when traveling. Dynaris assumes no liability for persons choosing not to adhere to recommendations.

WARNING: As stated here and in Dynaris’s IFU manuals, these devices are NOT INTENDED to be life sustaining or life supporting.

WARNING: Oxygen equipment may require unscheduled servicing during your travels. Please be advised that Dynaris cannot assure Patient that compatible equipment or proper support services will be available to Patient while traveling. Without limiting the generality of the foregoing, Dynaris has no capability to provide goods, repair, or clinical services to a Patient on an airplane, or outside of Dynaris local service area.

CAUTION: USA Federal law restricts portable oxygen devices to sale by or on the order of a physician. May also be applicable in other countries.

CAUTION: Manufacturer recommended nasal cannula should be used to ensure proper patient usage and oxygen delivery.

19. Website Terms of Use

Please read the following Website Terms of Use before using our website. All users of this site agree that access to the use of this site is subject to the following terms and conditions:

When you either visit Dynaris, call us, email us, or mail us, you are communicating with us. By doing so, you are consenting to receive communications from us. Periodically, we may communicate new information to you. You are welcome to opt out of any communications at any time.

All content included on this website is the property of Dynaris and is protected by the United States of America International Copyright Laws.

All logos and graphics are trademarks of Dynaris, it’s suppliers and web designers. No trademarks may be used in connection with any product or services not authorized by us or in any manner that may cause public confusion, or discredits Dynaris.

If a prescription is required for an item, we will verify the prescription prior to shipping or billing your credit card. Failure to supply a prescription, or our inability to verify prescription information, will result in a cancellation of the order after (30) days. If a check or money order has already been received, we will refund the full amount.

We stand behind the products we sell. We only work with reputable manufacturers and suppliers and if the need arises, we will work hard to help and facilitate any repair work on any item we sell. We will do our very best to make sure your experience with Dynaris is the best it can be. Please contact your primary oxygen provider for all reserve oxygen needs.

Please make sure to read our "Return Policy" prior to any purchase. It is up to the Purchaser to read and understand Dynaris's warranty/non-warranty coverage information provided.

20. Returns

Product returns will not be accepted by Dynaris unless written authorization has been obtained in advance in the form of a Return Material Authorization ("RMA") number, and the items are received by Dynaris in their **ORIGINAL** condition. When returning Product, Patient is required to include a copy of the original invoice or packing slip to ensure prompt issuing of credits. The RMA number must be written on the documents enclosed and on the outside of the shipping box. All return shipments are to be paid by the Customer. Accessories are not eligible for a return for credit. This credit minus the processing fee will be paid once Dynaris receives the Product back and the Product has been inspected to confirm all components are returned. If there are missing components, a partial credit may be given. This may take up to 10 business days after receipt of product at Dynaris. It is required that customers retain the original packing material for at least 30 days, in the event the device needs to be returned.

RETURN INSTRUCTIONS:

If you have received an item from Dynaris that needs repair, please contact Patient Support at 636-778-1926, Monday through Friday, to obtain a Return Authorization Number. All returns must be shipped within 5 days from receiving your Return Authorization Number.

Ship all returns to us at the following address:

Dynaris
743 Spirit 40 Park Drive
Suite 108
Chesterfield, MO 63005

REPAIRS OR REPLACEMENTS BEYOND WARRANTY:

For products returned for repair or replacement that are not covered under Product warranty, Patient shall contact Dynaris for instructions and assistance. Products may only be returned by Patient to a designated repair site, when accompanied by an RMA number issued by Dynaris. Freight expenses for Products returned by Patient will be paid by Customer. Patient shall pay for freight costs incurred for shipment back to Patient for Products repaired or replaced outside of warranty.

SERVICE AND REPAIR:

In all instances of customer-caused damage, the Patient is responsible for all parts, labor, and all shipping charges to return the device to Dynaris for repair. Please contact us for assistance at 636-778-1926. Every Apogee comes with a Manufacturer's Warranty. Please contact us so we may assist you with warranty repairs. The Patient is responsible for all shipping and handling charges both directions on any "In Warranty" or "Out of Warranty" repair. Patient is responsible for all repair, labor, and shipping charges (both directions), for any "Out of Warranty" repair. Service and Repair policy applies to all customers, both U.S. and International.

DAMAGED GOODS:

Once your package arrives, please ensure it is not damaged or defective in any way. Notification of returns for damaged products must be made within 72 hours of receiving your items. In this case a full credit will be issued for both the purchase and shipping costs.

REFUSED SHIPMENTS:

Refused shipments, products returned without the original packaging and orders canceled after the device has been shipped are subject to a 25% restocking fee and customers will be responsible for shipping charges both ways. Customers are not responsible for shipping costs associated with refusing equipment that has been damaged during Customers are not responsible for shipping costs associated with refusing equipment that has been damaged as long as the item is refused at the time of delivery and damage is noted on the “proof of delivery” form provided to for signature by the carrier.

21. Limited Warranty

LIMITED WARRANTY: Dynaris Apogee device Hardware Warranty

IMPORTANT: BY USING YOUR APOGEE DEVICE-BRANDED DYNARIS PRODUCT YOU ARE AGREEING TO BE BOUND BY THE TERMS OF THE APOGEE DEVICE THREE (3) YEAR LIMITED WARRANTY (“WARRANTY”) AS SET OUT BELOW. DO NOT USE YOUR PRODUCT UNTIL YOU HAVE READ THE TERMS OF THE WARRANTY. IF YOU DO NOT AGREE TO THE TERMS OF THE WARRANTY, DO NOT USE THE PRODUCT AND RETURN IT WITHIN THE RETURN PERIOD STATED IN DYNARIS’ RETURN POLICY TO DYNARIS OR AN AUTHORIZED DYNARIS DISTRIBUTOR.

HOW CONSUMER LAW RELATES TO THIS WARRANTY

THIS WARRANTY GIVES YOU SPECIFIC LEGAL RIGHTS, AND YOU MAY HAVE OTHER RIGHTS THAT VARY FROM STATE TO STATE (OR BY COUNTRY OR PROVINCE). OTHER THAN AS PERMITTED BY LAW, DYNARIS DOES NOT EXCLUDE, LIMIT OR SUSPEND OTHER RIGHTS YOU MAY HAVE, INCLUDING THOSE THAT MAY ARISE FROM THE NONCONFORMITY OF A SALES CONTRACT. FOR A FULL UNDERSTANDING OF YOUR RIGHTS YOU SHOULD CONSULT THE LAWS OF YOUR COUNTRY, PROVINCE OR STATE.

WARRANTY LIMITATIONS SUBJECT TO CONSUMER LAW

TO THE EXTENT PERMITTED BY LAW, THIS WARRANTY AND THE REMEDIES SET FORTH ARE EXCLUSIVE AND IN LIEU OF ALL OTHER WARRANTIES, REMEDIES AND CONDITIONS, WHETHER ORAL, WRITTEN, STATUTORY, EXPRESS OR IMPLIED. DYNARIS DISCLAIMS ALL STATUTORY AND IMPLIED WARRANTIES, INCLUDING WITHOUT LIMITATION, WARRANTIES OF MERCHANTABILITY AND FITNESS FOR A PARTICULAR PURPOSE AND WARRANTIES AGAINST HIDDEN OR LATENT DEFECTS, TO THE EXTENT PERMITTED BY LAW. IN SO FAR AS SUCH WARRANTIES CANNOT BE DISCLAIMED, DYNARIS LIMITS THE DURATION AND REMEDIES OF SUCH WARRANTIES TO THE DURATION OF THIS EXPRESS WARRANTY AND, AT DYNARIS’ OPTION, THE REPAIR OR REPLACEMENT SERVICES DESCRIBED BELOW. SOME STATES (COUNTRIES AND PROVINCES) DO NOT ALLOW LIMITATIONS ON HOW LONG AN IMPLIED WARRANTY (OR CONDITION) MAY LAST, SO THE LIMITATION DESCRIBED ABOVE MAY NOT APPLY TO YOU.

WHAT IS COVERED BY THIS WARRANTY?

Dynaris, 743 Spirit 40 Park Drive, Suite 108, Chesterfield, Mo 63005, (“Dynaris”) warrants the Dynaris-branded Apogee device hardware product and accessories contained in the original packaging (“Apogee device Product”) against defects in materials and workmanship when used normally in accordance with Dynaris’ published guidelines for a period of THREE (3) YEAR from the date of original purchase by the end-user purchaser (“Warranty Period”). Dynaris’ published guidelines include but are not limited to

information contained in technical specifications, user manuals and service communications. Shipping costs will be paid by Dynaris during the first year of the Limited Warranty. Shipping costs to be paid by the patient during the Limited Warranty year two and three.

WHAT IS NOT COVERED BY THIS WARRANTY?

This Warranty does not apply to any non-Dynaris branded hardware products or any non-Dynaris software, even if packaged or sold with Apogee device hardware. Manufacturers, suppliers, or publishers, other than Dynaris, may provide their own warranties to you – please contact them for further information. Software distributed by Dynaris with or without the Dynaris' brand (including, but not limited to system software) is not covered by this Warranty. Please refer to the licensing agreement accompanying the software for details of your rights with respect to its use. Dynaris does not warrant that the operation of the Dynaris Product will be uninterrupted or error-free. Dynaris is not responsible for damage arising from failure to follow instructions relating to the Dynaris Product's use.

This Warranty does not apply: (a) to consumable parts, such as batteries or protective coatings that are designed to diminish over time, unless failure has occurred due to a defect in materials or workmanship; (b) to cosmetic damage, including but not limited to scratches, dents and broken plastic on ports; (c) to damage caused by use with another product; (d) to damage caused by accident, abuse, misuse, liquid contact, fire, earthquake or other external cause; (e) to damage caused by operating the Dynaris Product outside Dynaris' published guidelines; (f) to damage caused by service (including upgrades and expansions) performed by anyone who is not a representative of Dynaris or an Dynaris Authorized Service Provider ("ASP"); (g) to an Dynaris Product that has been modified to alter functionality or capability without the written permission of Dynaris; (h) to defects caused by normal wear and tear or otherwise due to the normal aging of the Dynaris Product, or (i) if any serial number has been removed or defaced from the Dynaris Product. (j) shipping costs during the second and third year of the Limited Warranty.

IMPORTANT RESTRICTION FOR DYNARIS APOGEE DEVICE SERVICE.

Dynaris may restrict warranty service for the Apogee device to the country where Dynaris or its Authorized Distributors originally sold the device.

YOUR RESPONSIBILITIES

Before receiving warranty service, Dynaris may require that you furnish proof of purchase details, respond to questions designed to assist with diagnosing potential issues and follow Dynaris' procedures for obtaining warranty service. Before submitting your Dynaris product for warranty service you should maintain a separate backup copy of the contents of its storage media, remove all personal information that you want to protect and disable all security passwords.

DURING WARRANTY SERVICE IT IS POSSIBLE THE CONTENTS OF THE STORAGE MEDIA COULD BE DELETED AND REFORMATTED. DYNARIS AND ITS AGENTS ARE NOT RESPONSIBLE FOR ANY LOSS OF SOFTWARE PROGRAMS, DATA OR OTHER INFORMATION CONTAINED ON THE STORAGE MEDIA OR ANY OTHER PART OF THE DYNARIS PRODUCT SERVICED.

Following warranty service, your Dynaris product or a replacement device will be returned to you as your Dynaris Product was configured when originally purchased, subject to applicable updates. Dynaris may install system software updates as part of warranty service that will prevent the Dynaris product from reverting to an earlier version of the system software.

Important: Do not open the Dynaris Apogee Device product. Opening the Dynaris Apogee Device product may cause damage that is not covered by this Warranty. Only Dynaris or an ASP (Approved Service Provider) should perform service on this Dynaris product.

HOW TO OBTAIN WARRANTY SERVICE?

Please access and review the online help resources described below before seeking warranty service. If the Dynaris product is still not functioning properly after making use of these resources, please contact a Dynaris representative, using the information provided below. A Dynaris representative or ASP will help

determine whether your Dynaris product requires service and, if it does, will inform you how Dynaris will provide it. When contacting Dynaris via telephone, other charges may apply depending on your location. Online information with details on obtaining warranty service is provided below.

LIMITATION OF LIABILITY

EXCEPT AS PROVIDED IN THIS WARRANTY AND TO THE MAXIMUM EXTENT PERMITTED BY LAW, DYNARIS IS NOT RESPONSIBLE FOR DIRECT, SPECIAL, INCIDENTAL OR CONSEQUENTIAL DAMAGES RESULTING FROM ANY BREACH OF WARRANTY OR CONDITION, OR UNDER ANY OTHER LEGAL THEORY, INCLUDING BUT NOT LIMITED TO LOSS OF USE; LOSS OF REVENUE; LOSS OF ACTUAL OR ANTICIPATED PROFITS (INCLUDING LOSS OF PROFITS ON CONTRACTS); LOSS OF THE USE OF MONEY; LOSS OF ANTICIPATED SAVINGS; LOSS OF BUSINESS; LOSS OF OPPORTUNITY; LOSS OF GOODWILL; LOSS OF REPUTATION; LOSS OF, DAMAGE TO, COMPROMISE OR CORRUPTION OF DATA; OR ANY INDIRECT OR CONSEQUENTIAL LOSS OR DAMAGE HOWSOEVER CAUSED INCLUDING THE REPLACEMENT OF EQUIPMENT AND PROPERTY, ANY COSTS OF RECOVERING, PROGRAMMING, OR REPRODUCING ANY PROGRAM OR DATA STORED IN OR USED WITH THE DYNARIS PRODUCT OR ANY FAILURE TO MAINTAIN THE CONFIDENTIALITY OF INFORMATION STORED ON THE DYNARIS PRODUCT. THE FOREGOING LIMITATION SHALL NOT APPLY TO DEATH OR PERSONAL INJURY CLAIMS, OR ANY STATUTORY LIABILITY FOR INTENTIONAL AND GROSS NEGLIGENT ACTS AND/OR OMISSIONS. DYNARIS DISCLAIMS ANY REPRESENTATION THAT IT WILL BE ABLE TO REPAIR ANY APOGEE DEVICE UNDER THIS WARRANTY OR REPLACE THE DYNARIS PRODUCT WITHOUT RISK TO OR LOSS OF INFORMATION STORED IN THE DYNARIS PRODUCT. SOME STATES (COUNTRIES AND PROVINCES) DO NOT ALLOW THE EXCLUSION OR LIMITATION OF INCIDENTAL OR CONSEQUENTIAL DAMAGES, SO THE ABOVE LIMITATION OR EXCLUSION MAY NOT APPLY TO YOU.

PRIVACY

Dynaris will maintain and use Patient information in accordance with the Dynaris Patient Privacy Policy available at www.dynaris.com/legal/internet-services/privacy.

GENERAL

No Dynaris reseller, agent, or employee is authorized to make any modification, extension, or addition to this Warranty. If any term is held to be illegal or unenforceable, the legality or enforceability of the remaining terms shall not be affected or impaired. This Warranty is governed by and construed under the laws of the country in which the Dynaris product purchase took place. Dynaris or its successor in title is the warrantor under this Warranty.

REVISION CONTROL DOCUMENT

LTF-2021-003
LTF-2021-011
LTF-2022-006

END OF DOCUMENT